

Introduction

The LCE-789014-EM is an emulation board or daughterboard for the LCE-K0S development system for NEC's 8-bit μ PD789014 subseries microcontrollers. Combining this board with the LCE-78K0S allows you to efficiently emulate any μ PD789014 subseries device. The LCE-789014-EM is shipped with the following contents:

- ❑ LCE-789014-EM daughterboard
- ❑ This manual
- ❑ One 50-pin ribbon cable
- ❑ CD-ROM containing debugger, compiler, assembler, and documentation

Figure 1. System Configuration

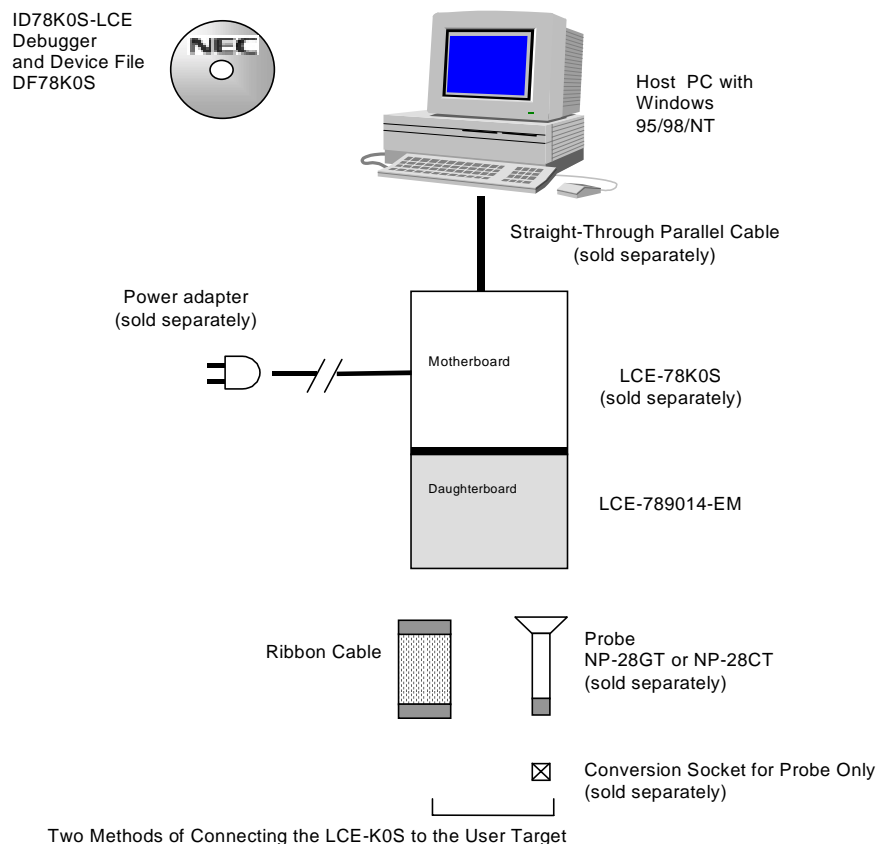

Two Methods of Connecting the LCE-K0S to the User Target

Table 1. Basic Specification

Parameter	Description
Target device	μPD789011
	μPD789012
	μPD78P901
Clock supply	Internal: installed on the motherboar
	External: pulse input
Low-voltage compatible	At least 2 volts

Components

The LCE-789014-EM daughterboard mates with the LCE-78K0S motherboard. In other words, the top of the daughterboard faces down in the system. As shown in Figure 2, a top view of the daughterboard, U1 is the Realchip that provides peripherals unique to the μPD789014 subseries devices.

Figure 2. Top View of Daughterboard

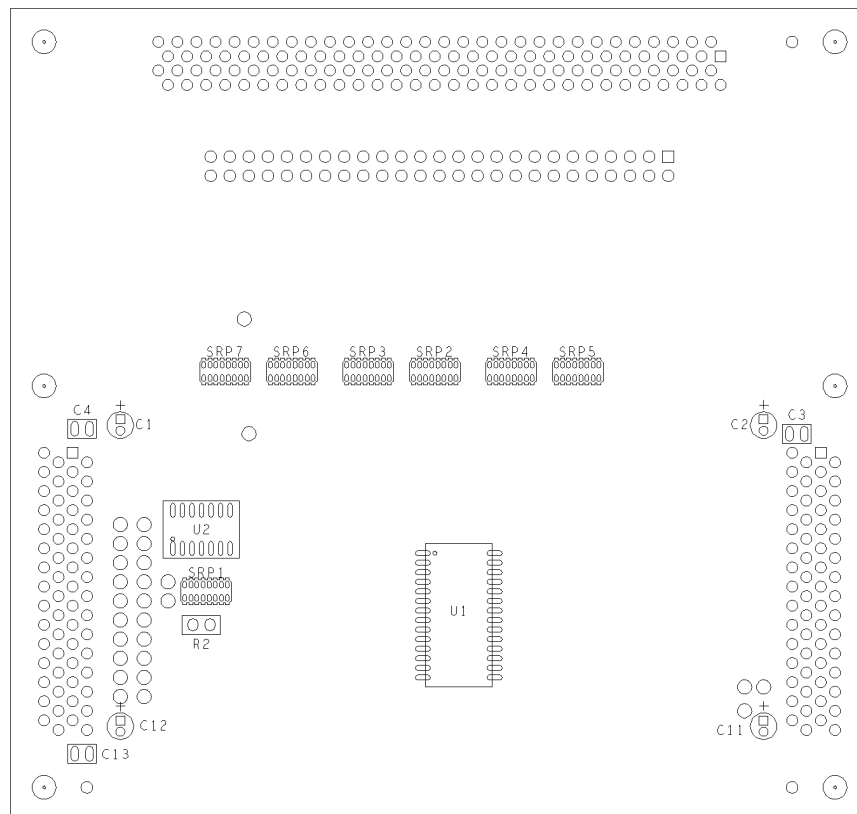

In the bottom view shown in Figure 3, J1 and P1 are connectors to the user target that contain all of the pins available on the device. J1 is a KEL connector for the probe, while P1 is a dual-row, male-shrouded header with latching levers for the ribbon cable. P3 and P4 are connectors for the motherboard, which attaches to the top of the daughterboard.

Figure 3. Bottom View of Daughterboard

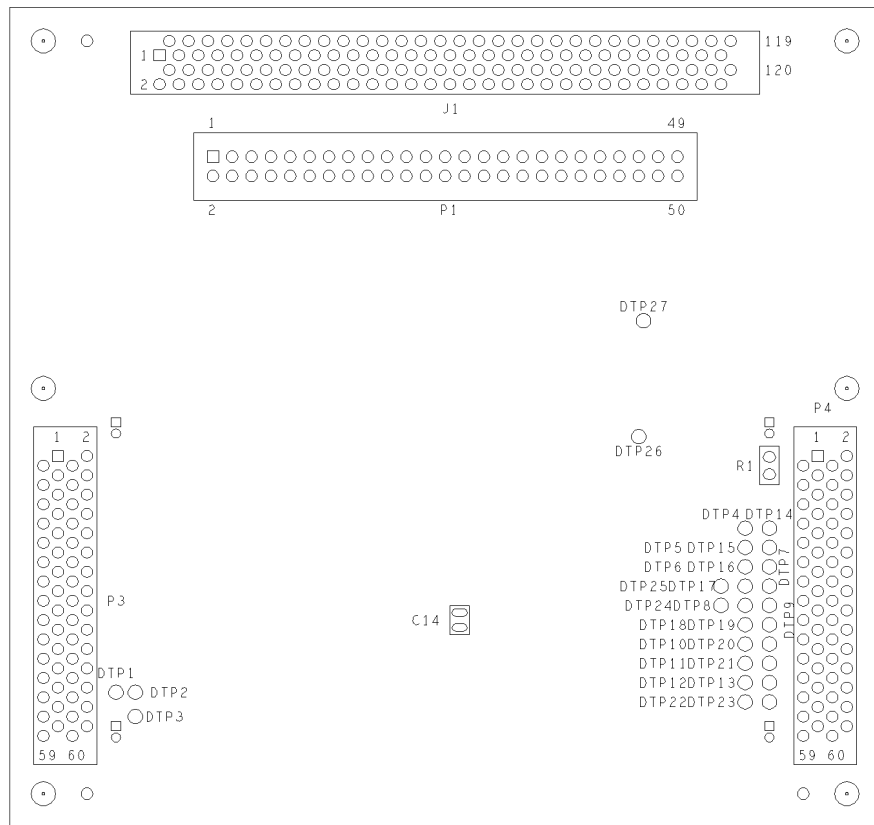

Ribbon Cable

The ribbon cable is a 50-pin female-to-female cable that connects the LCE-K0S to the user target. Alternatively, an emulation probe may be used. One end of the ribbon cable connects to the daughterboard and the other to the target. The side of the ribbon cable with a red stripe is pin 1.

Table 2. P1 Pin Assignment

P1 Connector	μPD78901x Device Pin	Signal	Note
1			GND on probe cable
2			GND on probe cable
3			GND on probe cable
4			GND on probe cable
5			GND on probe cable
6			GND on probe cable
7			GND on probe cable
8			GND on probe cable
9			GND on probe cable
10			GND on probe cable
11	1	P31/INTP1/T11/TO1	
12	2	P32/INTP2	

Table 2. P1 Pin Assignments (continued)

P1 Connector	μPD78901x Device Pin	Signal	Note
13	3	VPP	
14	4	RESET	
15	5	X2	
16	6	X1	
17	7	VSS	
18	8	VDD	
19	9	P00	
20	10	P01	
21	11	P02	
22	12	P03	
23	13	P04	
24	14	P05	
25	15	P06	
26	16	P07	
27	17	P10	
28	18	P11	
29	19	P12	
30	20	P13	
31	21	P14	
32	22	P15	
33	23	P16	
34	24	P17	
35	25	P20/ASCK/SCK0	
36	26	P21/TXD/SO0	
37	27	P22/RXD/SI0	
38	28	P30/INTP0/TI0/TO0	
39			GND on probe cable
40			GND on probe cable
41			GND on probe cable
42			GND on probe cable
43			GND on probe cable
44			GND on probe cable
45			GND on probe cable
46			GND on probe cable
47			GND on probe cable
48			GND on probe cable
49			GND on probe cable
50			GND on probe cable

Emulation Probe (Optional)

In place of ribbon cables, an emulation probe can be used to connect the LCE to the user target, provided the user target has a conversion socket/adaptor installed.

Table 3. Emulation Probe Pin Assignments

Emulation Device Pin No.	J1 Pin No.	Emulation Device Pin No.	J1 Pin No.
1	70	15	21
2	69	16	22
3	72	17	18
4	102	18	19
5	71	19	55
6	104	20	49
7	103	21	56
8	27	22	23
9	61	23	24
10	62	24	29
11	65	25	30
12	66	26	93
13	92	27	94
14	91	28	99

Table 4. Emulation Probe and Socket for μ PD789014 Subseries

Target Device	Emulation Probe + Conversion Socket/Adapter
μ PD789011GT	NP-28GT + 28GT-IC DUMMYSET
μ PD789012GT	
μ PD78P9014GT	
μ PD789011CT	NP-28CT + generic DIP socket
μ PD789012CT	
μ PD78P9014CT	

Assembly

This procedure explains how to connect the LCE-789014-EM to the LCE-78K0S motherboard.

1. Connect the probe or ribbon cable to their respective connectors on the LCE-789014-EM (Figure 4).

Figure 4. Connections for Emulation Probe or Ribbon Cables

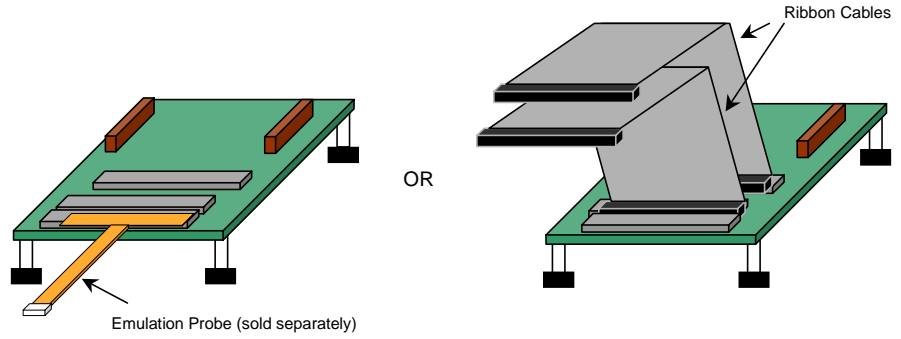

2. Make sure power is off from the LCE-K0S motherboard.
3. Remove the two screws at the bottom of the standoffs on the motherboard (Figure 5).

Figure 5. Screws on Bottom of Motherboard

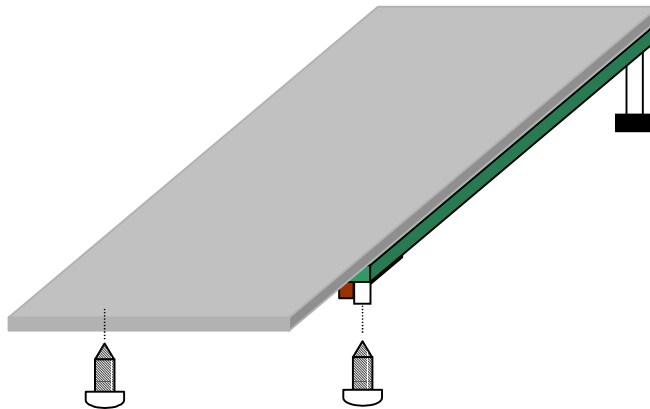

4. With the daughterboard on a stable surface, connect the motherboard on the daughterboard by gently applying pressure on the mating connectors. Avoid applying pressure on the plastic cover (Figure 6).

Figure 6. Daughterboard Mating Connectors

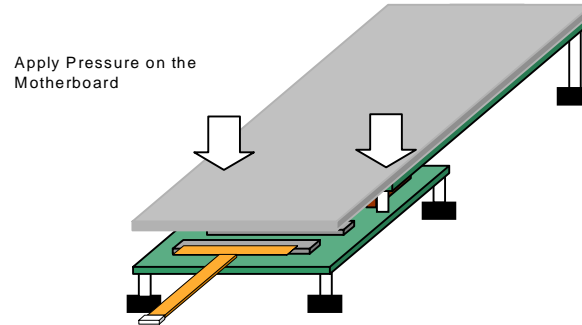

5. Replace the screws on the bottom of the daughterboard to securely connect it to the motherboard (Figure 7).

Figure 7. Connection to Motherboard

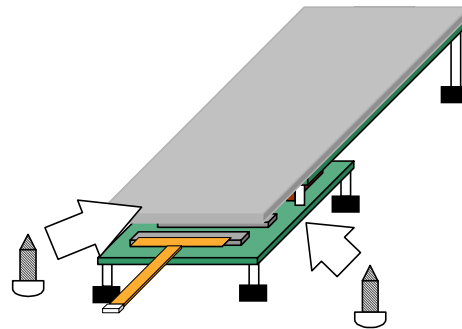

6. Connect the loose end of the probe or ribbon cable to the user target. Refer to Table 2 and Table 3 for pin assignments.

7. With a 25-pin male-to-male parallel cable (not included), connect the LCE-K0S system to the host computer (Figure 8).

Figure 8. Connection to Host PC

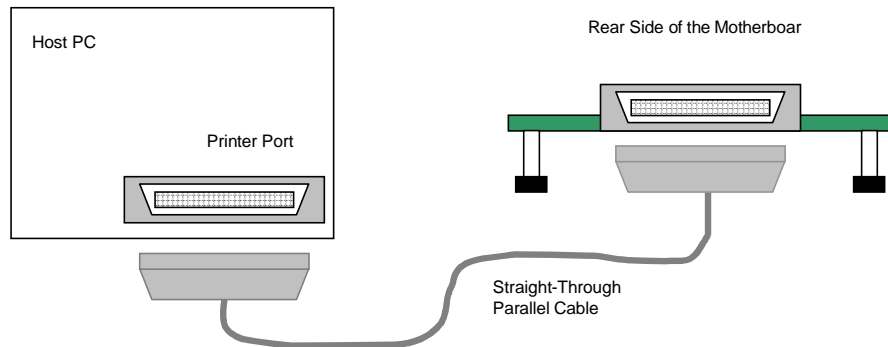

8. With the power adapter connected, turn the switch to the ON position. The green LED turns on when power is supplied to the system.
9. Launch the debugger from your PC.

NEC

For literature, call **1-800-366-9782** 7 a.m. to 6 p.m. Pacific time
or FAX your request to **1-800-729-9288**
or visit our web site at **www.necel.com**

In North America: No part of this document may be copied or reproduced in any form or by any means without the prior written consent of NEC Electronics Inc. (NECEL). The information in this document is subject to change without notice. All devices sold by NECEL are covered by the provisions appearing in NECEL Terms and Conditions of Sales only. Including the limitation of liability, warranty, and patent provisions. NECEL makes no warranty, express, statutory, implied or by description, regarding information set forth herein or regarding the freedom of the described devices from patent infringement. NECEL assumes no responsibility for any errors that may appear in this document. NECEL makes no commitments to update or to keep current information contained in this document. The devices listed in this document are not suitable for use in applications such as, but not limited to, aircraft control systems, aerospace equipment, submarine cables, nuclear reactor control systems, and life support systems. "Standard" quality grade devices are recommended for computers, office equipment, communication equipment, test and measurement equipment, machine tools, industrial robots, audio and visual equipment, and other consumer products. For automotive and transportation equipment, traffic control systems, anti-disaster and anti-crime systems, it is recommended that the customer contact the responsible NECEL salesperson to determine the reliability requirements for any such application and any cost adder. NECEL does not recommend or approve use of any of its products in life support devices or systems or in any application where failure could result in injury or death. If customers wish to use NECEL devices in applications not intended by NECEL, customer must contact the responsible NECEL salespeople to determine NECEL's willingness to support a given application.



For literature, call **1-800-366-9782** 7 a.m. to 6 p.m. Pacific time
or FAX your request to **1-800-729-9288**
or visit our web site at **www.necel.com**

In North America: No part of this document may be copied or reproduced in any form or by any means without the prior written consent of NEC Electronics Inc. (NECEL). The information in this document is subject to change without notice. All devices sold by NECEL are covered by the provisions appearing in NECEL Terms and Conditions of Sales only. Including the limitation of liability, warranty, and patent provisions. NECEL makes no warranty, express, statutory, implied or by description, regarding information set forth herein or regarding the freedom of the described devices from patent infringement. NECEL assumes no responsibility for any errors that may appear in this document. NECEL makes no commitments to update or to keep current information contained in this document. The devices listed in this document are not suitable for use in applications such as, but not limited to, aircraft control systems, aerospace equipment, submarine cables, nuclear reactor control systems, and life support systems. "Standard" quality grade devices are recommended for computers, office equipment, communication equipment, test and measurement equipment, machine tools, industrial robots, audio and visual equipment, and other consumer products. For automotive and transportation equipment, traffic control systems, anti-disaster and anti-crime systems, it is recommended that the customer contact the responsible NECEL salesperson to determine the reliability requirements for any such application and any cost adder. NECEL does not recommend or approve use of any of its products in life support devices or systems or in any application where failure could result in injury or death. If customers wish to use NECEL devices in applications not intended by NECEL, customer must contact the responsible NECEL salespeople to determine NECEL's willingness to support a given application.



For literature, call **1-800-366-9782** 7 a.m. to 6 p.m. Pacific time
or FAX your request to **1-800-729-9288**
or visit our web site at **www.necel.com**

In North America: No part of this document may be copied or reproduced in any form or by any means without the prior written consent of NEC Electronics Inc. (NECEL). The information in this document is subject to change without notice. All devices sold by NECEL are covered by the provisions appearing in NECEL Terms and Conditions of Sales only. Including the limitation of liability, warranty, and patent provisions. NECEL makes no warranty, express, statutory, implied or by description, regarding information set forth herein or regarding the freedom of the described devices from patent infringement. NECEL assumes no responsibility for any errors that may appear in this document. NECEL makes no commitments to update or to keep current information contained in this document. The devices listed in this document are not suitable for use in applications such as, but not limited to, aircraft control systems, aerospace equipment, submarine cables, nuclear reactor control systems, and life support systems. "Standard" quality grade devices are recommended for computers, office equipment, communication equipment, test and measurement equipment, machine tools, industrial robots, audio and visual equipment, and other consumer products. For automotive and transportation equipment, traffic control systems, anti-disaster and anti-crime systems, it is recommended that the customer contact the responsible NECEL salesperson to determine the reliability requirements for any such application and any cost adder. NECEL does not recommend or approve use of any of its products in life support devices or systems or in any application where failure could result in injury or death. If customers wish to use NECEL devices in applications not intended by NECEL, customer must contact the responsible NECEL salespeople to determine NECEL's willingness to support a given application.